

TD-402S Desktop Shipping Label Printer

User Manual

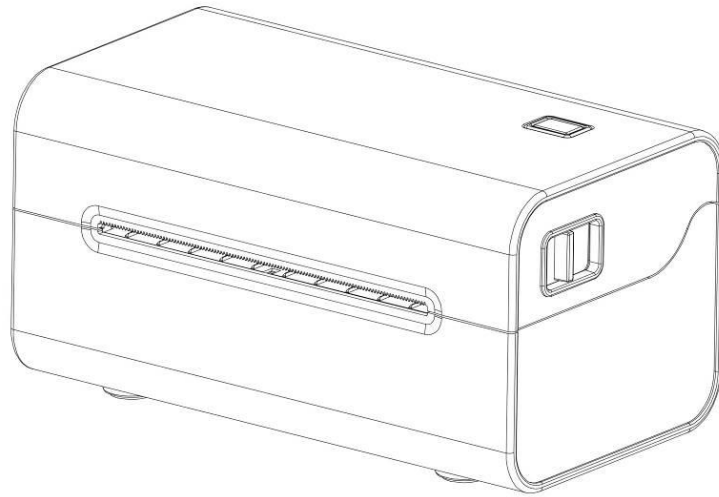

Table of Contents

I. Product Introduction

- 1.1 Safety Warnings
- 1.2 Key Features

II. Safety Instructions

III. Appearance and Components

IV. Technical Specifications

- 4.1 Printer Specifications

V. Installation and Operation of Printer

- 5.1 Printer Unpacking
- 5.2 Connecting the Printer
- 5.3 Loading Paper
- 5.4 Bluetooth Pairing and Printing
- 5.5 Use Bluetooth Interface for Printing

VI. The Button and Indicator Light of Printer

- 6.1 Power Switch
- 6.2 Keys and Indicators

VII. Printer Test

- 7.1 Print Self-test Page
- 7.2 Print with the Windows Driver
- 7.3 Label Learning

VIII. Cleaning the printer

- 8.1 Cleaning the Printhead
- 8.2 Cleaning the Sensor
- 8.3 Cleaning the Printing Roller

IX. Troubleshooting

I. Product Introduction

Thank you for purchasing the Desktop Shipping Label Printer. The attractive desktop printer delivers superior performance at an economical price. Both powerful and easy-to-use, widely used in

- ◆ Retail
- ◆ Food & Beverage
- ◆ Apparel
- ◆ Transportation & Logistics

.....

1.1 Warning

Warning 1: Do not touch the paper tear-off device above the front of the printer.

Warning 2: The printing head is a heating component. Do not touch the print head and surrounding components during or immediately after printing to avoid risk of heat burns.

Warning 3: Do not touch the surface of the thermal print head and connectors, to avoid electrostatic damage to the print head.

Warning 4: Please stay away from the radio equipment during printing. The printer may be interfered with by the radio.

1.2 Key Features

- ❖ Outstanding Printing Performance And Quality
- ❖ Quiet Operation
- ❖ Aesthetics in product design
- ❖ Compact, Use and Maintenance Friendly
- ❖ Fast print speeds - up to 1 pages per second
- ❖ Excellent heat dissipation performance, can handle large amounts of continuous works.
- ❖ Repeat function.

Illustrations and descriptions in this manual may differ from actual products.

II. Safety Precautions

Before operating and using the printer, please carefully read the following items and strictly observe the use rules.

1. The printer should be placed in a stable location to avoid vibration and shock.
2. Do not use or store the printer in locations with high temperatures, high humidity, or heavy soiling.
3. Connect the printer's power supply to a grounded outlet. Avoid using the same outlet as a large motor or other device that can cause voltage fluctuations in the power supply.
4. Avoid water or conductive materials (such as metal) entering the printer, and turn off the power immediately if water or conductive materials enter the printer.
5. Do not use the printer without paper, otherwise it will seriously damage the printing rubber roller and thermal head.
6. In the event that the printer is not in use for an extended period, it is advisable to disconnect the power supply from the printer power adapter.
7. It is not permitted for users to disassemble the printer for maintenance or modification without prior authorization.
8. Use only the power adapter specified in this instruction.
9. To ensure optimal printing quality and printer longevity, we recommend using the recommended or equivalent thermal printing paper.
10. Please ensure that the printer power is turned off when removing and inserting the cable.
11. When removing and inserting the power cable of the printer, please ensure that you hold the arrow of the power connector of the printer (do not remove or insert the flexible cable of the power cable of the printer).

This manual should be kept for future reference.

III. Appearance and Components

Desktop Barcode Printer

Front View

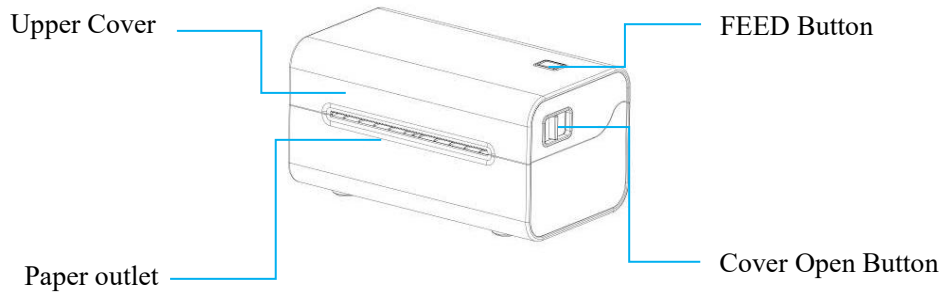

Rear View

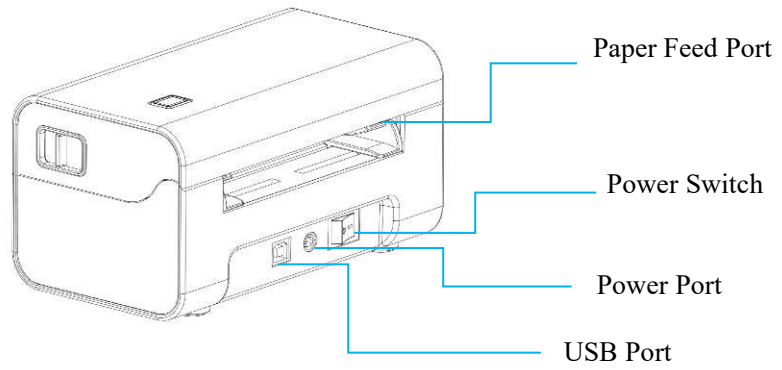

Inside View

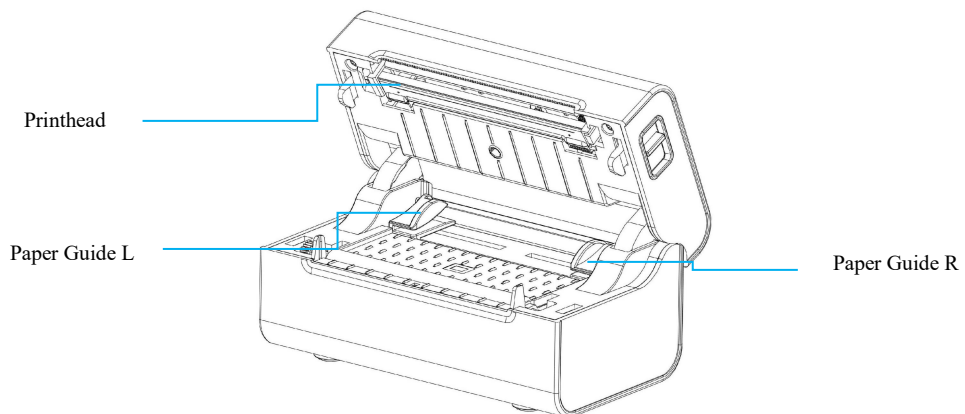

IV. Technical Parameters

4.1 Printer Parameters

Printing Parameters	
Model	TD-402S
Print Methods	Direct Thermal
Print Speed	150mm/s (max)
Resolution	203dpi
Media Thickness	0.06-0.26mm
Max. Print Width	108 mm
Max. Print Length	1778 mm
Printhead Life	150 Km
Interface	USB/BLE/WIFI
Media Sensors	Gap sensor/Open cover sensor/Black mark sensor
Memory	SRAM: 512K SDRAM: 8M
Fonts Size	9x17dot, 12x24dot, 24x24dot
Print Fonts	
Fonts	GBK
Extended Character List	PC437, Katakana, PC850, PC860, PC863, PC865, West Europe, Greek, Hebrew, East Europe, Iran, WPC1252, PC866, PC852, PC858, IranII, Latvian, Arabic, PT151 , 1251、PC747, WPC1257, Vietnam, PC864, PC1001, Uygur, Thai
2D Barcode	QR code, PDF417, Micro PDF 417, DataMatrix, AZTEC
Character Enlargement/Rotation	1-10x magnification/0°, 90°, 180°, 270° rotation/mirror printing/white printing
Power supply	
Power adapter	Input: 100~240V 50/60Hz
Input power supply	Output: 4V -2.5A
Environment Condition	
Operating Environment	Temperature: 5°C-40°C Humidity: 20-90% non-condensing
Storage Environment	Temperature: -10°C-60°C Humidity: 10-90% non-condensing
Order	
Operating Systems	Windows/Mac/Linux
Supported Command	TSPL
Media	
Paper Types	Thermal paper
Label Types	Die-cut, continuous, black mark, fan-fold
Label Width	30~114mm
Label Thickness	0.06-0.26mm
Core I.D.	/

Notes: The standard port is USB. Please note that other ports can be selected. For further details about the ports, please refer to the relevant objects.

V. Installation and Operation of Printer

5.1 Unpacking and Inspection

Before use, ensure the accessories are included in the package (the following picture is an example). If any thing is missing, contact the supplier or manufacturer.

Please note that the availability of the interface will determine whether the specific accessories are included.

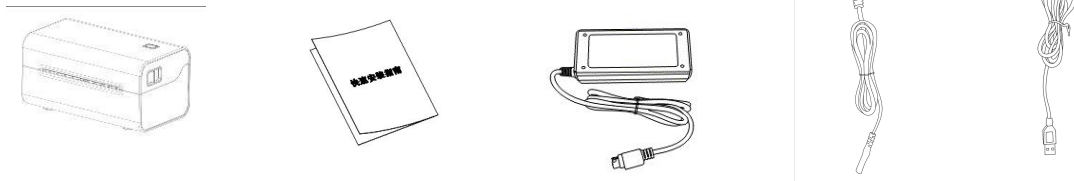

Printer*1

Quick Installation Guide*1

Power Adapter*1

Power Cord*1

USB Cable*1

The pictures are for reference only, please subject to practicality.

5.2 Connecting the Printer

Connect the power line

1. Place the printer on a flat, secure surface.
2. Make sure the power switch is off (○).
3. Connect the power adapter to the printer
4. Plug the power cord into the AC power cord socket at the rear of the printer, and then plug the power cord into a properly grounded power outlet.

Use the special power adapter for the printer, as the following pictures:

Connect the USB Cable

1. Connect the USB cable to the printer.
2. Connect the USB cable to the PC.
3. Turn the power switch to on.

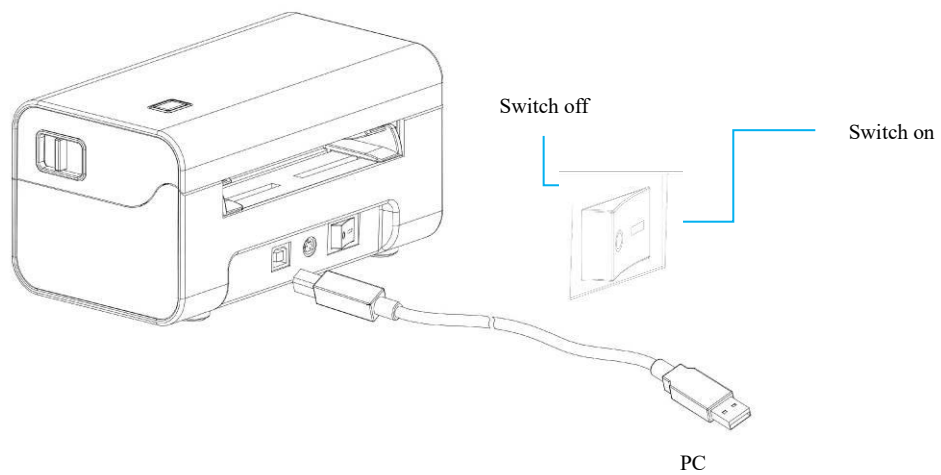
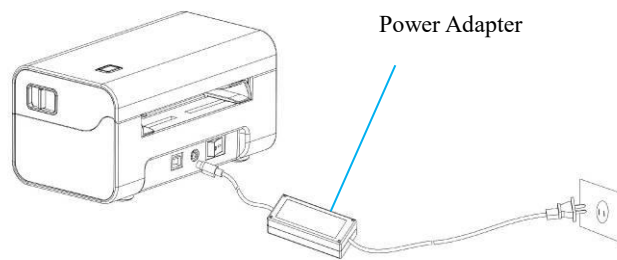

5.3 Loading Paper

The printer uses thermal paper rolls and has an easy paper loading structure.

The loading method of external thermal paper roll is as follows:

1. Ensure that the paper roll printing side is upward, and put the front end of the paper roll through the feed port on the back of printer.
2. Please insert the front end of the paper roll into the guide slot and pull it out over the roller. Please ensure that the guide block is closed according to the width of the paper in order to secure both sides of the paper.
3. Close the upper cover of the printer and press down gently until the top cover closes with a “click” sound.

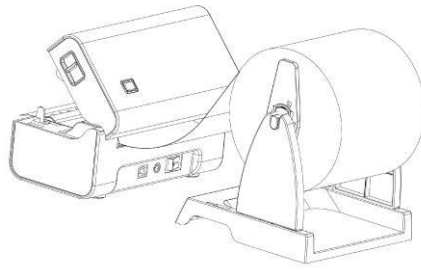

①

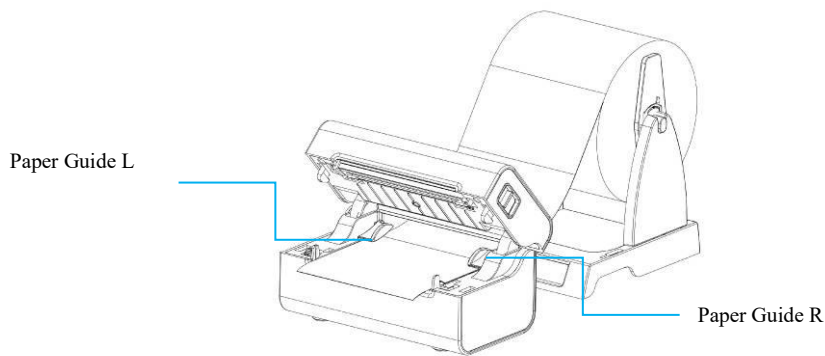

②

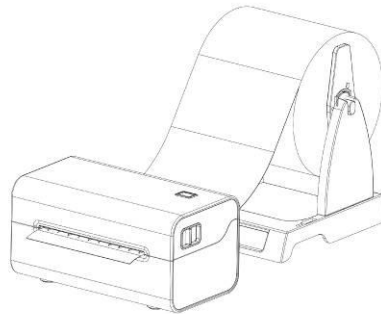

③

5.4 Bluetooth pairing and printing (only valid for printers with Bluetooth)

TD-402S Bluetooth printer must be paired with the master device that controls the printer. The pairing process is initiated by the master device.

The standard pairing procedure is as follows:

1. Turn on the printer
2. The main device searches for external Bluetooth device
3. If there are multiple external Bluetooth device, select the printer corresponding to Bluetooth MAC address (see self-test page for details).
4. Enter the initial password “0000” or “1234”

5. Complete the pairing

Please refer to the main device Bluetooth function description for specific pairing methods. Please note that when pairing, the printer with Bluetooth interface must be in standby mode.

Note: During pairing, do not turn on multiple printers at the same time, otherwise you may not be able to judge which printer was successfully paired.

Please note that the printer device can support a maximum of one Android device and one iOS device simultaneously. If more host computers are paired with the printer, the host that is paired with the printer at the earliest will be automatically removed from the pairing list by the printer. Please note that if the host machine requires the printer to be used for printing, it must be paired again (only applies to multi-connected Bluetooth devices).

5.5 Use Bluetooth interface for printing (only valid for printers with Bluetooth)

For host computers with virtual Bluetooth serial ports (such as Smartphone, Laptop, Desktop computer, etc.), after successful pairing, printing data can be sent to the printer via the virtual Bluetooth serial port for printing. If the host computer does not have a virtual Bluetooth serial port, please connect the printer driver to print.

5.5.1 The printing operation of the PC connected to the Bluetooth interface is as follows: (For illustrative purposes, we will use the serial port/network data debugger as an example.)

1. The laptop can be paired with the printer that needs to be connected via the system's Bluetooth function (shown in Figs.1 to 4).

2. Once the printer has been successfully paired, please use the host computer software (such as a serial port/network data debugger, etc.) to select the corresponding virtual Bluetooth serial port for connection.

3. Once the Bluetooth serial port connection has been established, enter the print command in the data sending area and click the “Send” button to print. (Shown in Fig.5).

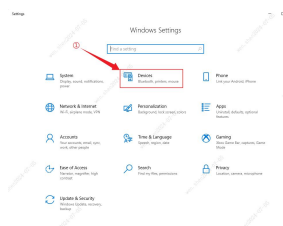

Fig.1

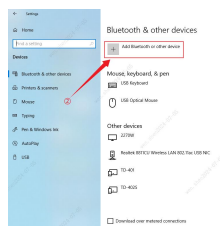

Fig.2

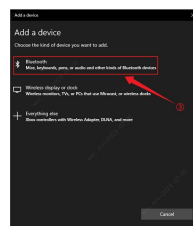

Fig.3

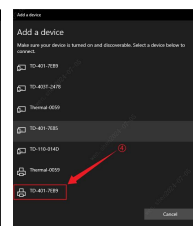

Fig.4

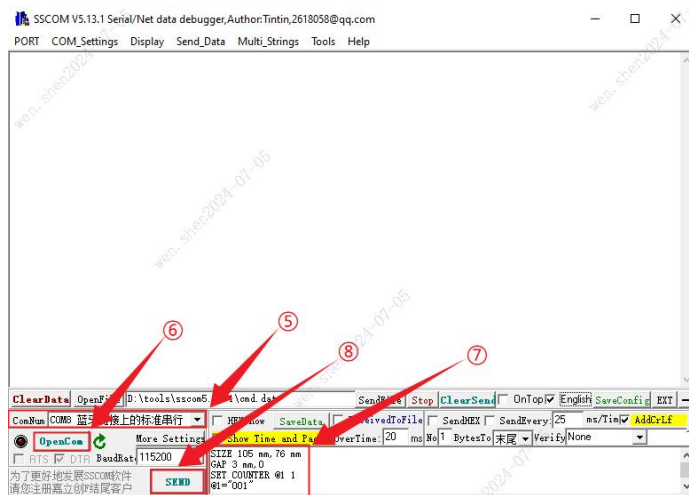

Fig.5

Note: Desktop computers require a Bluetooth adapter to print, whereas a Bluetooth module is built-in to the laptop.

5.2.2 The mobile terminal connects to the Bluetooth interface through the APP to print

Open the “TPL Print” APP, and select the TD-402S model from the list of available options. Once you have done this, enter the APP screen. Click the printer icon in the top right of the APP, enter the interface and select the Bluetooth name of the printer to connect. Once connected, the APP can send print jobs to the printer via Bluetooth.

Note: Bluetooth matching is divided into two types: simple pairing and matching code pairing.

- ① Simple pairing does not require a Bluetooth password.
- ② Matching code pairing requires a Bluetooth password.
- ③ The Bluetooth name and password can be queried in the self-check page by printing the self-check page

5.6 Use WIFI interface for printing (only valid for the printers with WIFI)

TD-402S WIFI printer must be paired with the master device that controls the printer. The pairing process is initiated by the master device.

5.6.1 Please find below the configuration method for the Mobile WIFI:

1. Turn on the printer
2. The main device searches for external WIFI device (e.g. router), and connect to WIFI network
3. Use the “Feasy WiFi” APP to configure Bluetooth network and complete network configuration
4. Enter the router password and wait until the WiFi network is configured

Note:

To set up the network with the "Feasy WiFi" APP, connect the printer's Bluetooth on the Bluetooth Provisioning page.

When using a Bluetooth network, it is recommended that you do not turn on multiple printers at the same time.

If there are more than one external Bluetooth device, you can print the self-check page to see the Bluetooth name and MAC address.

Please note the last four characters of the Bluetooth name.

5.6.2 Please find below the configuration method for the PC WIFI:

1. Turn on the printer, and connect the computer and printer with a USB cable
2. Open the label machine setting tool (printer_setting_boxed.exe) on the computer and select “WiFi settings”.
3. Once the “STA Mode” has been enabled, please enter the name and password of your external WiFi network (e.g. router) and confirm (shown in Fig.1).
4. Select “wifi_ip Settings” and click “Read” to obtain IP information (shown in Figs.2 and 3).

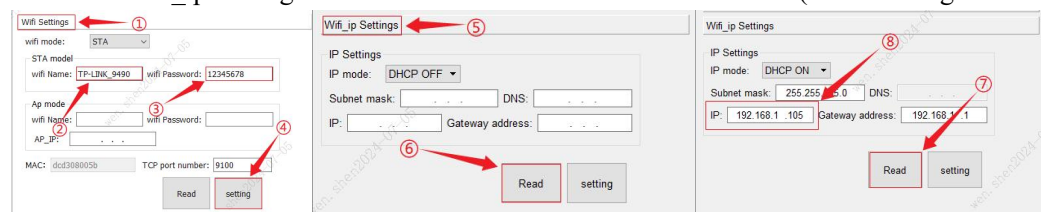

Fig.1

Fig.2

Fig.3

5.6.3 In AP mode, users can connect directly to the printer hotspot without the need for a network.

The procedure is as follows:

1. Open the label machine setting tool on the computer and select "WiFi Setting" in the setting tool.
2. Switch the WiFi mode to “AP” and click “Setting”.
3. Once the AP IP address has been set, click on the “Read” button to obtain the AP IP address (shown in Figs.4 and 5).

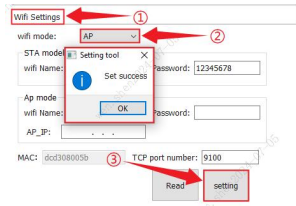

Fig.4

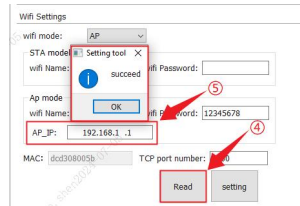

Fig.5

Note: When utilising the label setting tool, it is important to distinguish between “STA Mode” and “AP Mode”. In both modes, you can query IP address information by printing the self-check page.

5.7 Print via WiFi port (driver does not support WiFi printing).

5.7.1 The PC is connected to the WiFi port

Connect the desktop computer to the WiFi network hotspot (e.g. router) in “STA Mode” or the printer hotspot in “AP Mode”, and use the host computer software (such as network debugging assistant, etc.). Enter the IP address and send printing instructions to the printer with WiFi through the wireless network.

Note: Laptop comes with WiFi module function, no need to plug in Wireless LAN Card.

1. The printer is in the startup ready state. Please insert the wireless network card into the PC and connect to the WiFi network hotspot configured by the printer.
2. Open the host software. In the host software: (1) Select "TCP Client" as the protocol type; (2) Enter the IP address obtained from the configuration in the Remote Host address field. (3) Enter the TCP port number: 9100.
3. Click the "Connect" button to establish a successful network connection.
4. Enter the print command in the data sending area and click the "Send" button to print (shown in Fig. 1).

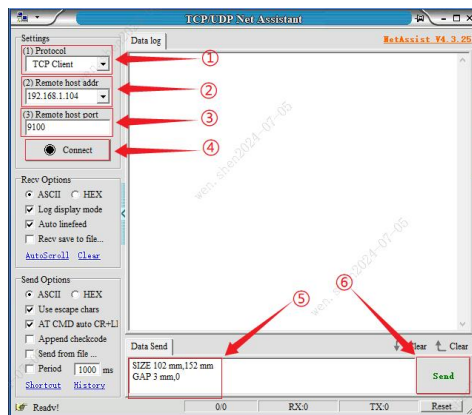

Fig.1

Note: The operation method of “AP Mode” is identical to that of “STA Mode”. The WiFi_IP address can be queried on the self-check page.

5.7.2 The mobile terminal connects to the WiFi interface through the APP to print

Open the “TPL Print” APP, and select the TD-402S model from the list of available options. Once you have done this, enter the APP screen. If in "AP Mode", please connect the mobile phone system WiFi to the printer WiFi. If in "STA Mode", please connect the mobile phone system WiFi to the printer configured WiFi hotspot. The printer WiFi name, password and IP address can be queried in the self-check page. Once the printer WiFi connection is successful, click the printer

icon in the upper right corner of the APP main interface, and then click the WiFi icon in the upper right corner of the interface. Enter the corresponding IP address and click "add printer". Once the connection has been established, the APP can send the print job to the printer via WiFi, which is connected to the wireless network.

Note: It is important to be able to distinguish between “STA Mode” and “AP Mode”. The default IP address for “AP Mode” is 192.168.1.1.

VI. The Switch, Key and Indicator Light of Printer

6.1 Power Switch

The power switch controls the flow of power to the printer. The power switch is located on the front side of the printer. When the “-” switch is pressed, the printer is turned on; When the “o” switch is pressed, the printer is turned off.

Note: Please ensure that the power supply is connected prior to activating the switch.

6.2 Keys and Indicators

Regular Button Function

Scenarios and Button Operation	Functions
Press and hold + turn on the printer (the buzzer has sounded once, release the button.)	Print self-test page
Press and hold + turn on the printer (the buzzer has sounded eight times, release the button.)	Restore factory settings
Short press (in a state of readiness)	Automatically feeding a blank label

Indicator description

Indicator Status	Status Description	
The indicator is always on	Normal standby	
The indicator flashes	Buzzer alarm	
Buzzer alarm (common)	2 sounds	Command error
	3 sounds	Paper shortage error
	5 sounds	Overheating error
	6 sounds	Cover opening error
	7 sounds	Gap label error

Note: TD-402S indicators have multiple definitions. Please refer to the actual indicator

VII. Printer Test

7.1 Print self-test page

When the printer is initially installed or there is a problem with the printer, you can run a self-test program to confirm the following status: firmware version, printer parameter setting status, print quality and related settings of external devices, etc. Once the self-test has been completed, please check other devices or software to confirm that the printer is not experiencing any issues. This function operates independently of other devices or software.

The self-test method is as follows:

1. Make sure the printer is connected to power supply and the paper roll is loaded correctly.
2. Make sure the printer is turned off and the top cover is closed in place.
3. Press and hold the FEED button, and then press the POWER button to turn on the printer, when the buzzer has sounded once, release the button.

7.2 Print with the Windows Driver

1. Install the Windows driver until the driver is installed.
2. Set the “port” of the Windows driver to the appropriate interface to use.
3. Print the test page with the “Print Test Page” function of Windows driver.

Note: Please refer to the “Windows Driver Installation and Printing Test Page Instructions” for further details.

7.3 Print with the Mac Driver

1. Install the Mac driver until the driver is installed.
2. The Mac driver printer has been successfully added, and the “Printer Queue” is displayed.
3. Print the test page with the “Print Test Page” function of Mac driver.

Note: Please refer to the “Mac Driver Installation and Printing Test Page Instructions” for further details.

7.4 Print with the Ubuntu Driver

1. Install the Ubuntu driver until the driver is installed.
2. The Ubuntu driver printer has been successfully added, and the “Printer Properties” is displayed.
3. Print the test page with the “Print Test Page” function of Ubuntu driver.

Note: Please refer to the “Ubuntu Driver Installation and Printing Test Page Instructions” for further details.

7.3 Label Learning

In the following cases, users can perform label positioning learning to enable the printer to position the label better:

- Install and use the printer for the first time.

- First use of printer after sensor cleaning.
- Reuse the printer after it is not used for a long time.
- Replace with a new type of paper roll.
- The printer cannot recognize the mark effectively during printing.
- The printer was restored to factory Settings.

7.6 Paper Shortage Learning

1. Put gap label in the printer and turn it on.
2. Connect the printer and computer via USB and open the label machine setting tool.
3. Once the printer is connected to the setting tool normally, the DAC self-learning process will begin.
4. Then, remove the label paper so that the printer is in a paperless state for the learning process.
5. Once the learning process is complete, pass the label through the guide block and use it normally.

7.7 Gap Label Learning

1. Put gap label in the printer and turn it on.
2. Connect the printer and computer via USB and open the label machine setting tool.
3. Once the printer is connected to the setting tool normally, the DAC self-learning process will begin.
4. Once you have completed the previous steps, proceed to use the setting tool "gap self-learning" button. Please wait for the printer to learn successfully.

7.8 Black Mark Label Learning

1. Put gap label in the printer and turn it on.
2. Connect the printer and computer via USB and open the label machine setting tool.
3. Once the printer is connected to the setting tool normally, the DAC self-learning process will begin.
4. Then, remove the gap label paper and put black mark label in the printer
5. Once you have completed the previous steps, proceed to use the setting tool "black mark self-learning" button. Please wait for the printer to learn successfully.

7.9 Paper Outlet Sensor Learning

1. Put gap label in the printer and turn it on.
2. Connect the printer and computer via USB and open the label machine setting tool.
3. Once the printer is connected to the setting tool normally, the DAC self-learning process will begin.
4. Expose the label to the paper outlet for a distance to ensure that the label tear line cannot back up to the paper outlet sensor before learning.
5. Once you have completed the previous steps, proceed to use the setting tool "paper outlet sensor self-learning" button. Please wait for the printer to learn successfully.

If the printer is learning in continuous paper mode, the learning is invalid.

Users use the Printer Tool software to complete the learning (refer to "Printer Setup Tool Instructions").

Note: ①After learning, you can re-open the top cover and place the blank label paper just fed during learning back for printing to avoid paper waste.

②Should the printer be in a state of misoperation for paper shortage learning, it is possible to put the printer in a state of no paper, paper learning can be performed again.

③Once the factory settings have been reinstated, should the printer fail to function as intended, it will be necessary to re-learn the printer in order to guarantee its optimal performance. The operation method is as follows:

- 1. Open the label machine setting tool and first carry out "DAC self-learning" (ensuring that the paper is gap paper).*
- 2. Once the DAC self-learning is complete, please carry out "gap self-learning".*
- 3. Once the gap learning is complete, please recycle the learning label paper, so that the printer is in a paperless state and carry out "paper out learning".*
- 4. Once the paper learning process is complete, the label must be exposed to the paper edge for a specified distance to ensure that the label tearing line cannot be retracted to the paper exit sensor before learning. This is followed by the "paper outlet sensor self-learning" process.*
- 5. The gap label paper should then be removed and placed into the black label paper. Finally, the "black mark self-learning" process is initiated.*

VII. Cleaning the Printer

8.1 Cleaning the Printhead

Clean the printhead when one of the following conditions occurs to the printer:

- (1) Printing is not clear.
- (2) A vertical column if the printed page is not clear.
- (3) The paper feeding noise is too loud.

The printhead cleaning steps are as follows:

- (1) Turn off the printer, open the upper cover and remove the paper if exists.
- (2) If printing has just been completed, wait for the printhead to cool completely.
- (3) Use a soft cotton cloth that has been wrung out and dipped in anhydrous ethanol to wipe the print head surface of any dust or stains (shown in Fig.1).
- (4) After waiting for absolute ethyl alcohol to volatilize completely, close the upper cover and try printing again.

8.2 Cleaning the Sensor

Clean the paper shortage sensor when one of the following conditions occurs to the printer:

- (1) In the printing process, the printer occasionally stops printing and alarms for paper shortage.
- (2) No alarm for paper shortage.

The paper shortage sensor cleaning steps are as follows:

- (1) Ensure that the printer is powered off, the cover is opened and the paper is removed.
And then wipe the dust and stains on the sensor surface with a soft cotton cloth that has been dipped in anhydrous ethanol (please wring out the cloth).
- (2) Once the anhydrous ethanol has been completely volatilised, close the upper cover and restart the machine.

8.3 Cleaning the Printing Roller

Clean the printing roller when one of the following conditions occurs to the printer:

- (1) Printing is not clear.
- (2) A vertical column of the printed page is not clear.
- (3) The paper feeding noise is too loud.

The printing roller cleaning steps are as follows:

- (1) Ensure that the printer is powered off, the cover is opened and the paper is removed.
- (2) Wipe the dust and stains on the sensor surface with a soft cotton cloth that has been dipped in anhydrous ethanol (please wring out the cloth).
- (3) Once the anhydrous ethanol has been completely volatilised, close the upper cover and restart the machine.

Note:

- (1) The power supply must be turned off during the daily maintenance of the printer.
- (2) Do not touch the surface of the printhead with hands and metal objects, and do not scratch the surface of the printhead, printing roller and sensor with tweezers and other tools.
- (3) The organic solvents such as gasoline and acetone shall not be used.
- (4) Wait until absolute ethyl alcohol is completely volatilized, then turn on the power supply to continue printing.

IX. Troubleshooting

The following table provides a list of common problems and solutions for the average operator. If you have attempted troubleshooting according to the following methods and the problem persists, please contact the customer service department of the manufacturer you purchased for further assistance.

Fault Phenomenon	Possible Cause	Solution
Power indicator does not illuminate	a. The AC plug and the power supply plug are not properly connected to the printer socket.	a. Check the power connection and confirm that the AC plug and the power supply plug are properly connected to the printer socket. b. Turn on the printer.
Unable to print	a. The communication cable is not properly connected to the printer and PC hose. b. Communication interface setting error. c. Print status error.	a. Reconnect the communication cable. b. Refer to 6.2 “Keys and Indicators” of the manual, and confirm whether the standby status indicator is always on.
Incomplete print content	a. The paper is not centered, left and right offset.	a. Adjust the paper position. b. Set the correct label size.
Incorrect positioning	a. Label learning is not performed. b. Wrong paper mode selected	a. Label learning is performed. b. Please refrain from utilising the setting tool to adjust parameters. Additionally, the paper type can be configured within the driver.
Poor Print Quality	a. Media is loaded incorrectly Print density/speed is not set properly. Dust or adhesive accumulation on the printhead.	a. Reload the paper. b. Please refrain from utilising the settings tool. c. Cleaning printhead/printing

	b. The printhead is damaged.	roller (refer to 8.1 “Cleaning the Printhead”/8.2 “Cleaning the Printing Roller”/8.3 “Cleaning the Printing Roller”) d. In the event that the printhead is damaged, please contact the customer service department of the manufacturer from whom you purchased the item for repair.
--	------------------------------	--